

The Titan Support System **from**

ISCHEBECK®

TITAN



- The world's leading falsework system
- Fast and versatile
- Lightweight, yet exceptionally strong

The Titan Support System from

ISCHEBECK®

TITAN

The Titan support system is recognised as the leading product in its field by many professionals in the construction and civil engineering industries.

Comprising two main components; legs and frames, together with a comprehensive range of accessories, the Titan support system offers one of the quickest, most effective and versatile means of providing rapid support and access solutions in an enormous variety of situations.

The system can be used in both 'flying table' and erect and dismantle applications and is ideal for multi-storey structures, water reservoirs and soffit situations where mobility and ease of handling are required.

With the majority of components being manufactured from high grade aluminium to patented designs, the Titan support system possesses an exceptionally high strength to weight ratio which facilitates rapid erection, whilst its excellent corrosion resistance and robust build quality assure long term durability.

The Titan support system is designed to reduce labour costs, increase site efficiency, improve safety and meet the demands of today's construction and civil engineering techniques.



The Titan Support System from

ISCHEBECK®

TITAN

- Lightweight components can be easily handled by one man
- Titan can be loaded up to 100kN per leg
- 2.4m of jack adjustment with jacks top and bottom
- Two components for fast, efficient erection and dismantling
- No loose fittings
- Rigid connection between Titan legs and frames self-aligns the system
- Continuous vertical slots on the Titan legs allow ledger frames to be positioned at convenient working heights
- One system suitable for erect and dismantle falsework and large, rigid flying tables for versatility and economy
- Modular components easily adapt to height and width variations
- Accessories include rocking headplates, guard post brackets, access platforms, cantilever frames and a full range of safety components.



Titan Legs

ISCHEBECK®

TITAN

Titan legs are available in four sizes, each with continuous vertical slots to allow ledger frames to be fitted quickly and securely at the optimum height. Titan screw jacks can be fitted at the top and bottom of each leg, offering vertical adjustment of up to 2.4m.

*Note: Length includes headplate and iflon disc

	Weight
Size 1	16kg
Size 2	18kg
Size 4	23kg
Size 6	29kg

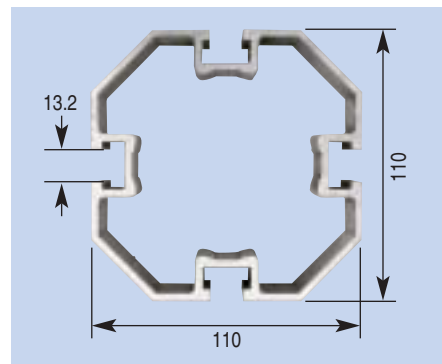
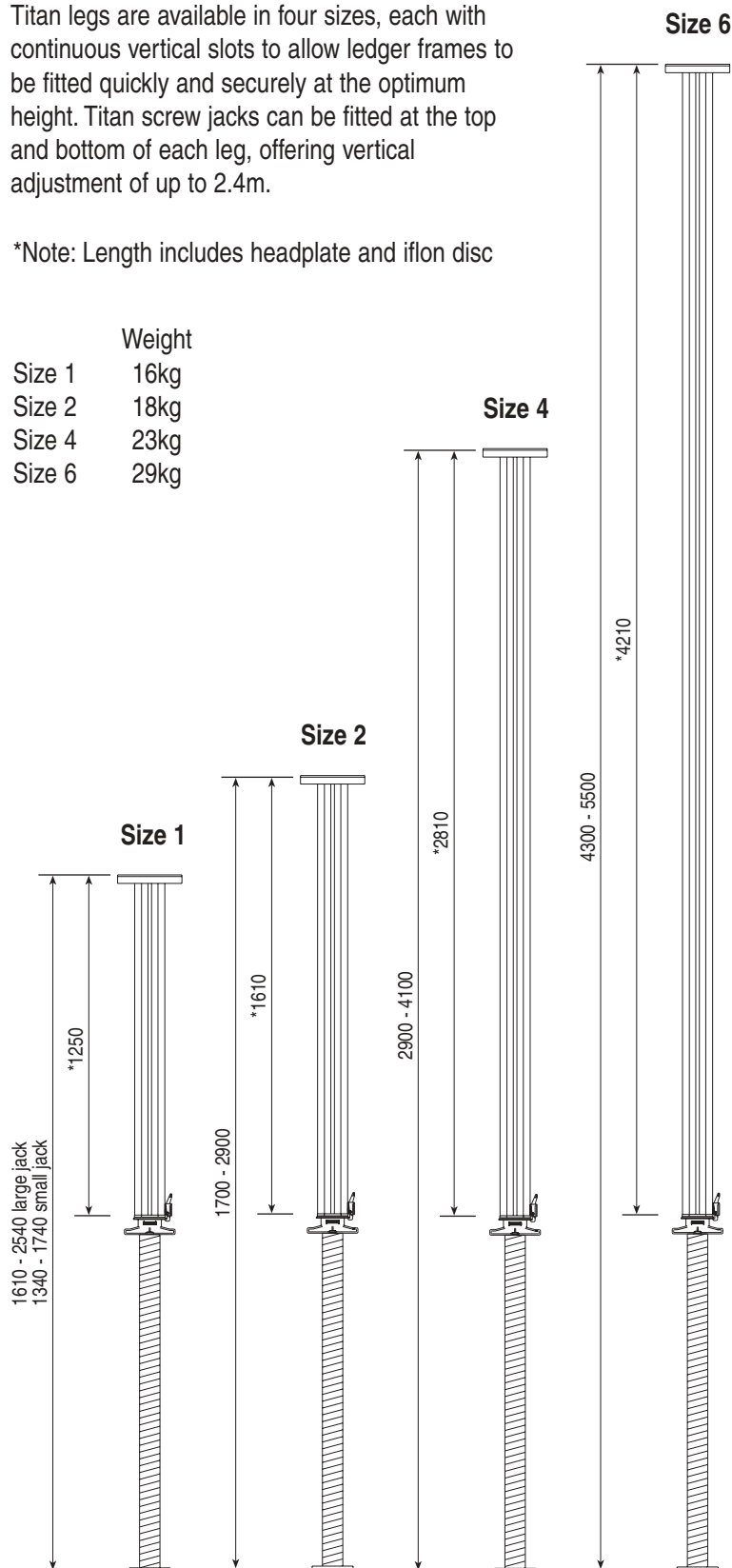

Profile

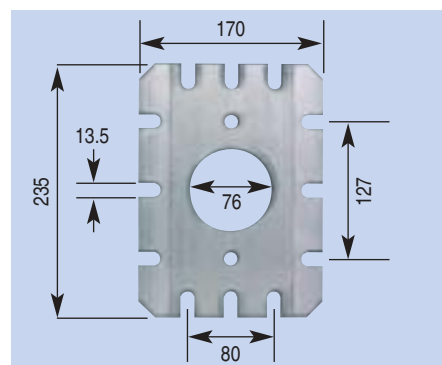

Headplate

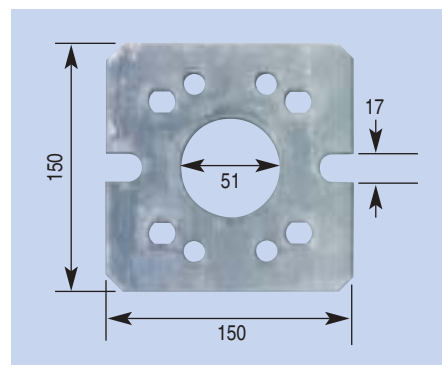

Baseplate



Retainer clips

Titan Ledger Frames

ISCHEBECK®

TITAN

A range of seven Titan ledger frames is available. All frames are shown colour coded in Ischebeck design drawings.

Note: Frame dimensions shown are in millimetres and centre-to-centre of Titan legs.

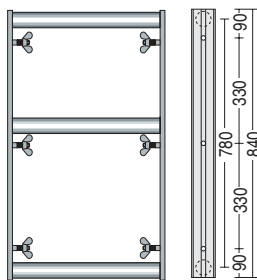

● 600 (5.6kg)

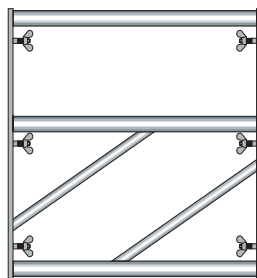
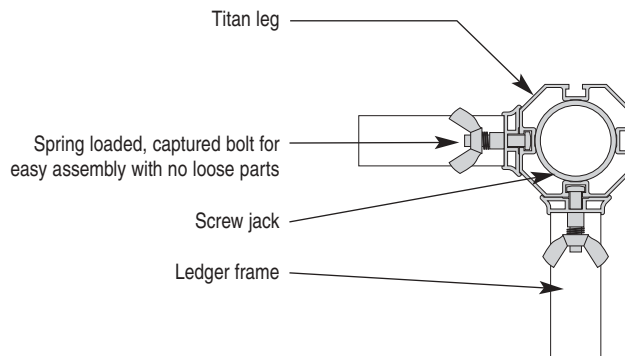

● 900 (7.5kg)

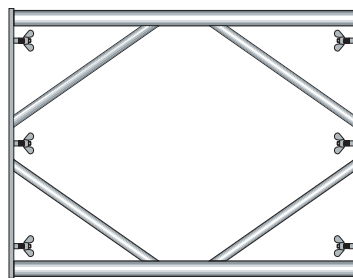

● 1200 (7.8kg)

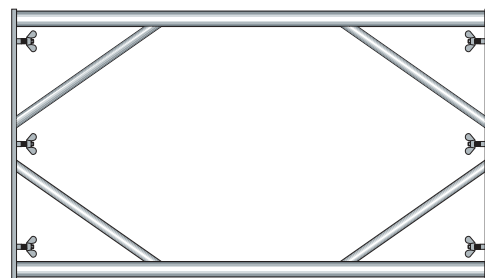

● 1600 (9.5kg)

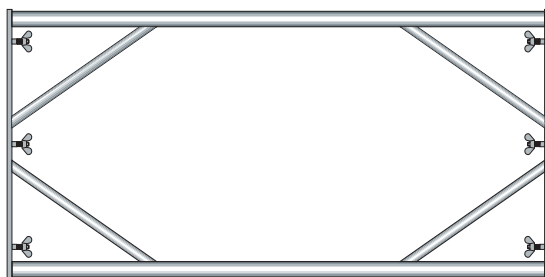

● 1800 (10.2kg)

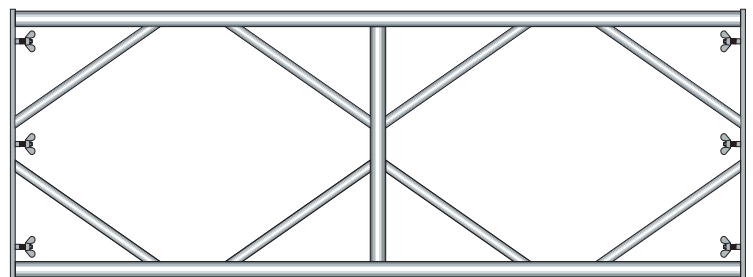

● 2400 (13.5kg)

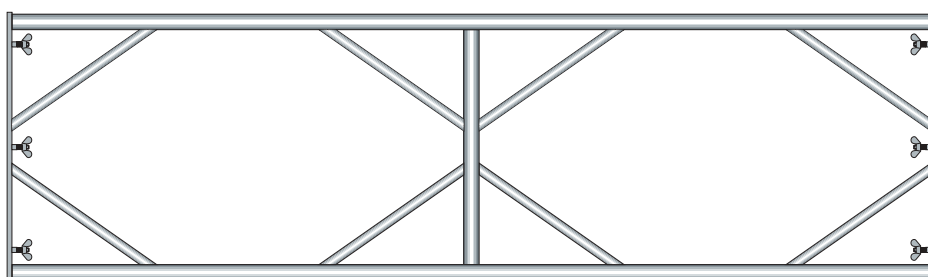

● 3000 (15.9kg)

The modular Titan system has been designed to combine maximum flexibility in use with a minimum number of components

The range of Titan accessories enhances the versatility of the Titan support system without adding significantly to the number of components or equipment required.

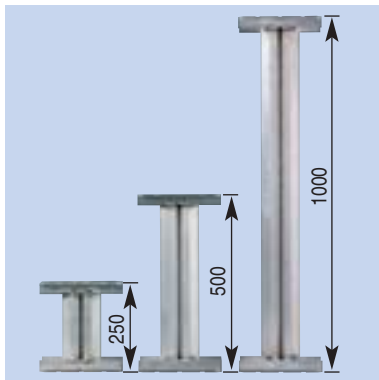

Titan extension piece
Extension pieces are available to make up non-standard heights.



Titan spanner
Simplifies jack adjustment.

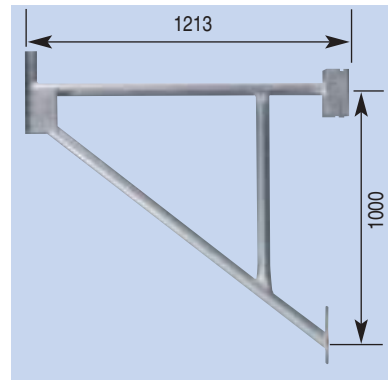

Titan Cantilever bracket
Provides external access and support.



Titan rocking head plate
For sloping soffits, ramps and other inclined surfaces.



Titan leg adaptor plate
For connecting to jack base plate.



Titan connecting bracket
Provides rapid connection between headplates.

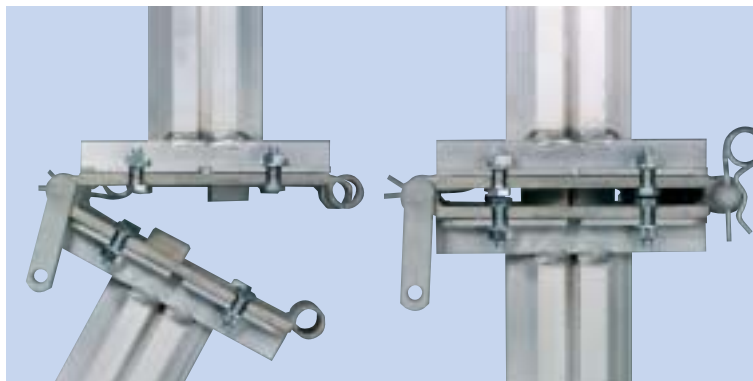

Titan hinge unit
For hinging of legs to clear narrow vertical openings.



Titan Trolley
For moving Titan system when assembled as a tableform.

Manufactured from extruded aluminium section, Titan beams offer a lightweight, easy to handle solution for decking/soffit applications. All secondary beams are shown colour coded in Ischebeck design drawings.

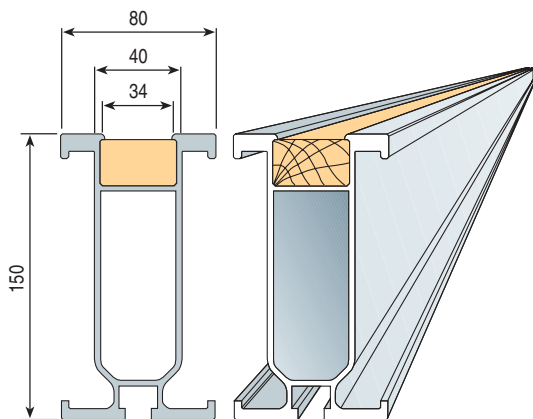
**Titan 150 beam**

	Area	18.6 cm ²
I _{xx}	Moment of inertia	596.9 cm ⁴
Z _{xx}	Section modulus	77.31 cm ³
E	Modulus of elasticity	68900N/mm ²
E.I.	Bending stiffness	411 kNm ²
W	Weight	5.63 kg/m
M	Resistance moment	11.9 kNm
S	Allowable shear force	30 kN

length (m)

1.2
1.8
2.4
2.7
3.0
3.6
4.2
4.8
5.4
6.0
6.4
7.2

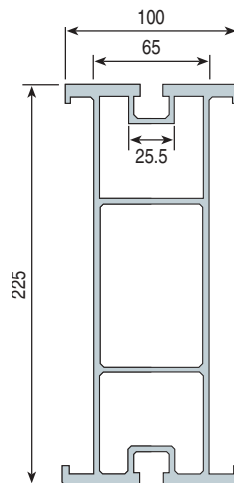
**Titan 225 beam**

	Area	32.63 cm ²
I _{xx}	Moment of inertia	2241 cm ⁴
Z _{xx}	Section modulus	199.2 cm ³
E	Modulus of elasticity	68900N/mm ²
E.I.	Bending stiffness	1544 kNm ²
W	Weight	8.87 kg/m
M	Resistance moment	28.5 kNm
S	Allowable shear force	71.3 kN

length (m)

1.2
1.8
2.4
3.0
3.6
4.2
4.8
5.4
6.0
6.4
7.2

length (m)

8.0
9.0
10.0
11.0

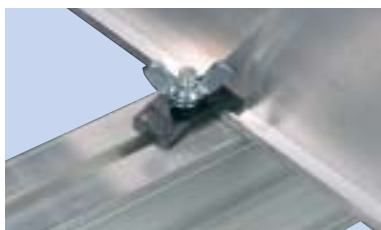
**Beam to beam fixing****Titan Clamp****Headplate to beam fixing**

Titan leg graph

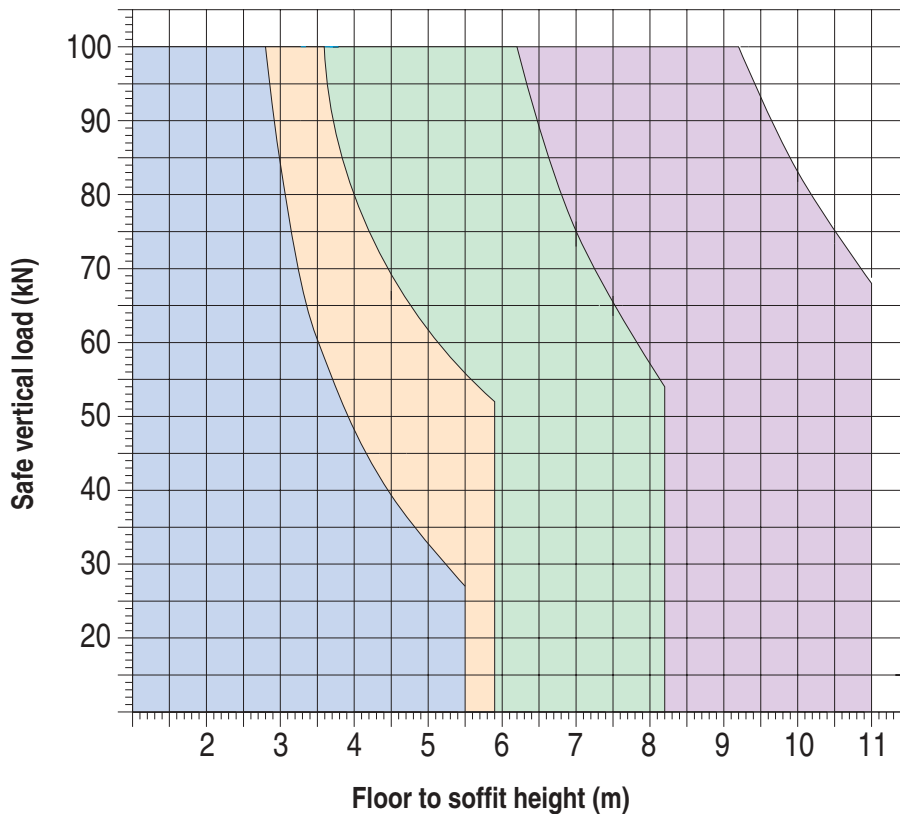

- Single leg
- 1 level of ledger frames in height
- 2 levels of ledger frames in height
- 3 levels of ledger frames in height

The allowable leg load is determined by the floor to soffit height, the number of ledger frames in height or jack extension

Notes:

Ledger frames to be fixed in the optimum position.

On higher propping heights an additional level of frames may be required for ease of erection and stability.

Maximum distance between ledger frames not to exceed 2.0 m.

Minimum height to base ratio = 3:1

It is assumed that formwork is restrained from horizontal movement at the formwork level.

Titan jack graph

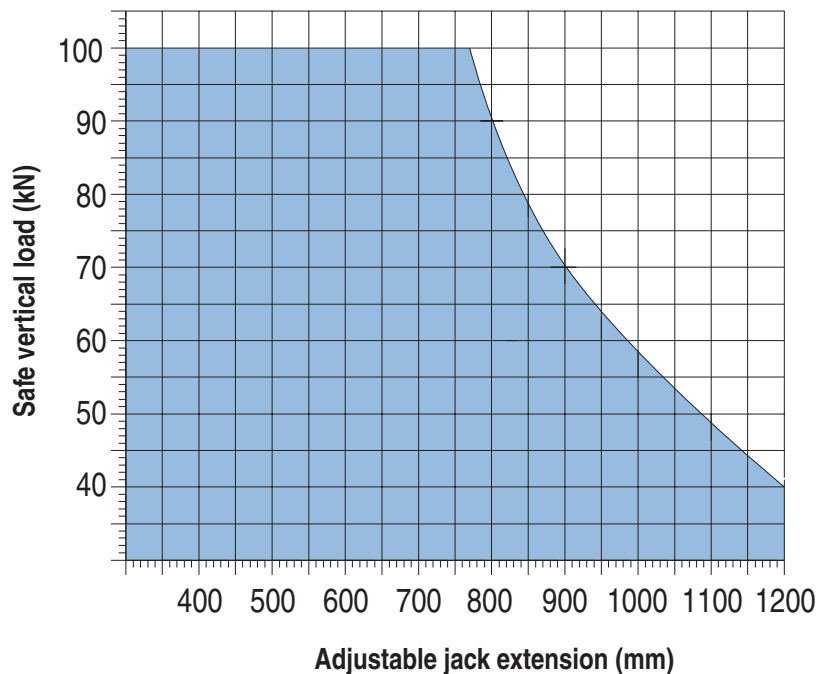

Designed to integrate with the Titan support system, Titan safety components provide the ideal means of assuring safety of site operatives and complying with health and safety at work requirements.



'C' hook
For removal of small edge tables.



Handrail frames
For protection around perimeter of work area.



Intermediate transom
For supporting scaffold boards.



Half coupler
For connecting scaffold tube to leg outer.



48 x 76 jack swivel coupler
For connecting scaffold tube to adjustable jack.



Guardpost bracket
For fixing of guardposts and handrails at soffit level.

Titan Erection Sequence

ISCHEBECK®

TITAN



1. Connect ledger frame horizontally between 2 legs. Predetermined ledger frame position measured from headplate.



2. Connect ledger frame vertically to leg.



3. Repeat 2 to form three sides to bay.



4. Repeat 1 to form 4th side of bay and then lift both sides of bay into position



5. Connect both sides to form a 4 leg tower.



6. Now add additional frames and legs to form Titan support structure.



7. Place intermediate transoms and scaffold boards in position for fixing of Titan aluminium beams.



8. Fix primary beam to headplate by means of 2 no. Titan clamps.



9. Position secondary beams and fix with a Titan clamp at each intersection with a primary beam. Structure is now ready for fixing of plywood.

* We recommend the use of Titan 'T' bolts with table assemblies

A Method Statement is available on request

Titan's versatility and light self weight make it the preferred choice for thousands of projects throughout the world's construction industry.



ISCHEBECK

TITAN



The Ischebeck Group

Founded in Germany over 120 years ago, Ischebeck is one of the world's principal manufacturers of formwork and falsework systems. Renowned internationally for its Titan support system, the group has a long standing tradition of innovation and engineering excellence. Product quality is a hallmark of the group and the company's manufacturing facilities are amongst the most advanced of their type.



Ischebeck Titan Limited

Ischebeck Titan is a leading supplier of formwork, falsework and related products to the construction industry. The company operates from headquarters centrally located in the heart of the U.K. along with regional offices in Scotland and the North of England.

Product Availability

Substantial stocks of equipment are available ex-stock from the company's strategically located 4-acre distribution site with most items available nationwide on a 48 hour delivery. Products are available for both hire and outright purchase.



Technical Support

Backed by the resources of one of the most respected names in the industry, Ischebeck Titan offers a comprehensive range of support services. The company's Technical Services Division can provide a full drawing and structural analysis service using the latest computerised equipment.

HEAD OFFICE

John Dean House
Wellington Road
Burton upon Trent
Staffordshire DE14 2TG
Tel: 01283 515677 Fax: 01283 516126
E-mail: sales@ischebeck-titan.co.uk

NORTHERN REGIONAL OFFICE & DESIGN OFFICE

Hollinwood Business Centre
Albert Mills Albert Street
Hollinwood Oldham OL8 3QP
Tel: 0161 682 4732
Fax: 0161 684 3603
E-mail: technical@ischebeck-titan.co.uk

Since our policy is one of continuous improvement we reserve the right to change without prior notice the specifications and methods of construction mentioned in this document. No responsibility whatsoever can be accepted for any errors or omissions in, or misinterpretation of the contents. Products must be used in conformity with safe practices and applicable codes and regulations. Photos and details shown are for general guidance only and may vary according to circumstances. For specific information refer to Ischebeck Titan Limited. Copyright reserved.