

Bridge parapet support bracket **from**

ISCHEBECK[®]

TITAN



Bridge parapet support bracket from

ISCHEBECK[®]

TITAN

A fast and effective way of forming parapets on bridges, the Parapet Bracket offers full adjustability and high carrying capacity. The high load capacity permits maximum spacing between brackets for maximum speed and economy.

The bracket is used to support Ischebeck TITAN aluminium decking

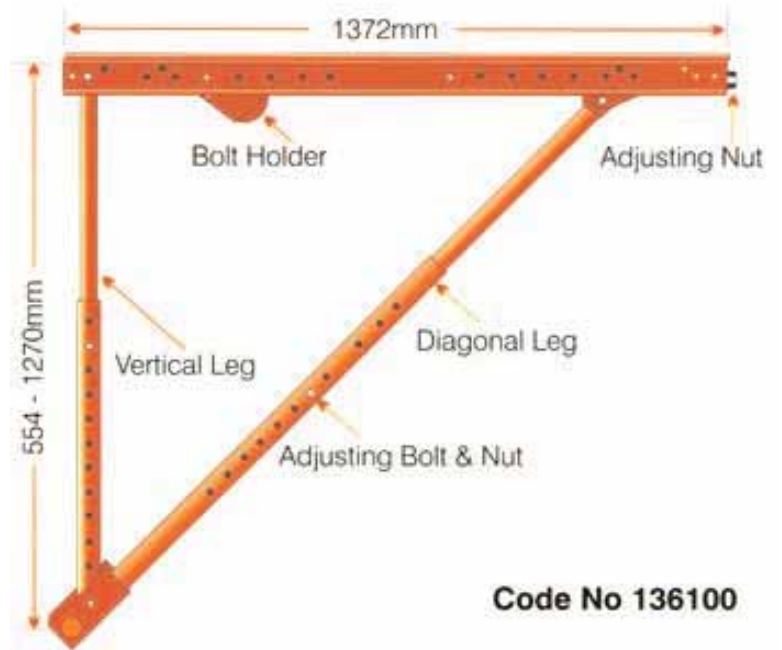

Bridge parapet support bracket from

ISCHEBECK®

TITAN

C-25 Half Hanger

The C-25 Half Hangers are used in situations where one-sided forming is required but welding to the top flange or rebar stirrups is not permissible.

Employing the 12.5mm coil rod/threaded bar as a horizontal tie connection, these hangers can be attached to the stirrup or stud with the adjustable U-clip shown. The exact location of the stirrup or stud is not critical due to the adjustability of this arrangement.

To ensure safe working loads, the 12.5 coil nuts on the threaded bar must be tightened down hard against the clip so that the stirrup or stud is securely clamped.

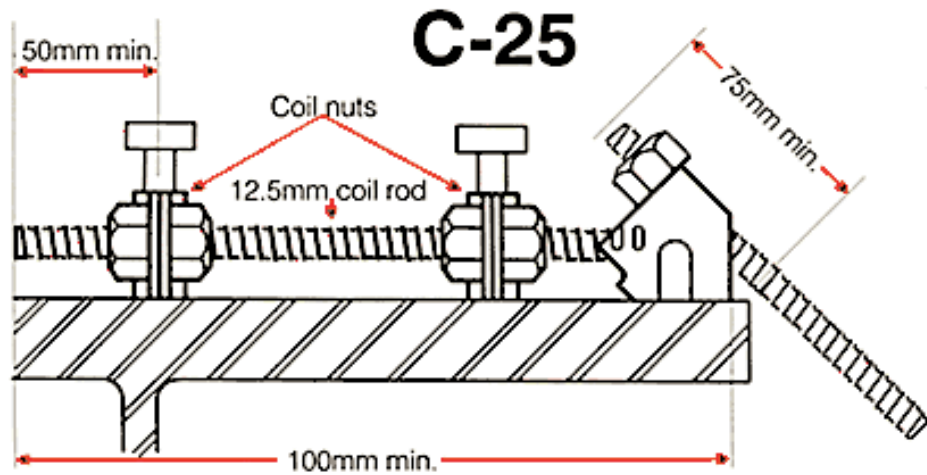

	Safe Working load
One Clip	500kg
Two Clips	1360kg

To fit rebar stirrups or welded studs

Adjustable U-clip

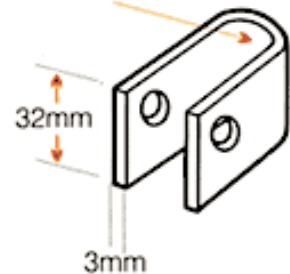

C-24 Cast in Hanger

The concrete must be thoroughly vibrated around the pigtail of the hanger and the hanger installed in such a manner that the bearing plate bears fully on the concrete beam.

Hanger Type	Safe Working load
C24 Type 1-AP	900kg
C24 Type 4-AP	1500kg

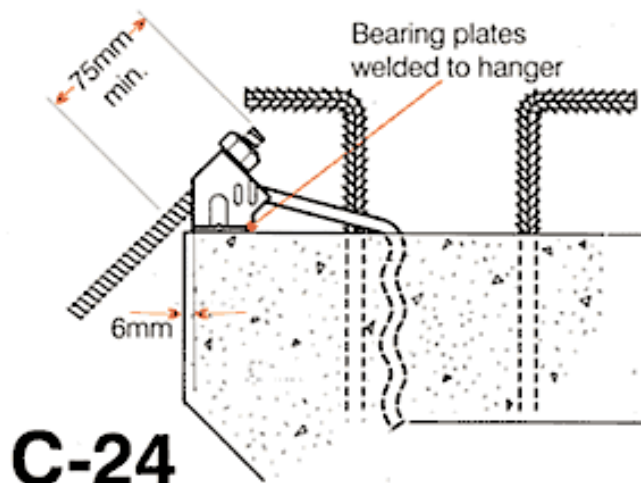

ISCHEBECK

TITAN



Ischebeck Titan Group

Founded in Germany over 120 years ago Ischebeck is renowned internationally for its aluminium formwork and false work systems, trench support systems and ground engineering products.

Ischebeck Titan Ltd

The company operates from headquarters centrally located in the heart of the UK.



Product Availability

Substantial stocks of equipment are available ex-stock from the company's strategically located 4-acre distribution site, with most main product lines available nationwide on a 48-hour delivery. Products are available for both hire and outright purchase.

Technical Support

We will participate in concept stage development. Providing input on applications, production rates, budget design, programming and costings. Active for on site support and training. We can provide guidance on industry special European and national standards.



HEAD OFFICE

John Dean House
Wellington Road
Burton upon Trent
Staffordshire DE14 2TG
Tel: 01283 515677 Fax: 01283 516126
www.ischebeck-titan.co.uk
E-mail: sales@ischebeck-titan.co.uk

NORTHERN REGIONAL OFFICE & DESIGN OFFICE

Hollinwood Business Centre
Albert Mills Albert Street
Hollinwood Oldham OL8 3QP
Tel: 0161 682 4732 Fax: 0161 684 3603
E-mail: technical@ischebeck-titan.co.uk

Since our policy is one of continuous improvement we reserve the right to change without prior notice the specifications and methods of construction mentioned in this document. No responsibility whatsoever can be accepted for any errors or omissions in, or misinterpretation of the contents. Products must be used in conformity with safe practices and applicable codes and regulations. Photos and details shown are for general guidance only and may vary according to circumstances. For specific information refer to Ischebeck Titan Limited. Copyright reserved.